



Alpha™ III



Leach Alpha™ III Rear Loader

THE STRONGEST MID-RANGE REAR LOADER

Every single day, Leach™ rear loaders prove just how reliable they are. They're built tough to handle even the most challenging routes. Leach™ is all about taking pride in the top-notch quality and productivity of every unit.

Every available option, every meticulously refined design, and every feature incorporated by Leach™ share a common goal: optimizing fleet efficiency while keeping maintenance costs at a minimum. Each Leach™ rear loader is meticulously crafted to provide the best product on the market with the lowest total cost of ownership.

The Leach Alpha™ III stands out as the most formidable mid-range rear loader, favored by more operators than any other truck. Featuring a standard 3.0 yd³ hopper, with the load sill positioned 5" below the chassis frame, and a rapid packing cycle time, it's no surprise that the Leach Alpha™ III has earned its reputation as a favorite.

Laying the foundations for a truly exceptional product.

LEACH™ INNOVATIONS

With a strong emphasis on innovation, Leach's engineering team has crafted a comprehensive range of customizable options to cater to even the most stringent customer requirements. We are poised and eager to embrace emerging industry trends and fulfill evolving customer demands. This perpetual cycle of innovation positions Leach™ as the forefront leader in side loader solutions across North America.

WEIGHT DISTRIBUTION

Over years of innovation, Leach™ trucks prioritize ideal weight distribution in all models. Our ongoing objective is to achieve the perfect material balance, ensuring models collect more waste while maintaining the highest legal payload.



ENVIROLINK™ HAS LAID THE FOUNDATIONS FOR A BRAND-NEW ERA IN TRUCK INTELLIGENCE.

An improved multiplex network and analog system, cameras and monitors, scales, diagnostic tools, safety interlocks, alerts, GPS tracking, and more are now packaged in a more precise, reliable, and efficient Smart Collection Package.



Diamond Force compaction design

Variety of lighting packages available with protective guards

Large 3.0 yd³ hopper

Ejector cylinder angled upward away from debris

14 yd³ to 32 yd³ body sizes available

Single piece body side sheet construction

Multiple commercial collection configurations available

Low sill height

LEACH	Alpha™ III	AUTOMATED	MANUAL	RESIDENTIAL	COMMERCIAL	DEMOLITION	ORGANICS	ALLEYS TIGHT AREAS	RECYCLING	TIPTO DUMP	FULL EJECT	SPLIT BODY	50>82 DGE	50>96 DGE	50>100 DGE	60>97 DGE	FRAME	ROOF	CAB	TAILGATE	EV	
			●	●	●				●	●					◇ CNG		◇ CNG	◇ CNG	◇ CNG		●	



DIAMOND FORCE COMPACTION

Our Diamond Force Compaction design evenly distributes trash, minimizing voids in the payload for a compaction rating of at least 1,000 lbs per cubic yard*.



CHROMIUM SLIDE SHOES

Slide shoes with Chromium carbide components operate in upper and lower rails, ensuring superior durability over AR450. Greaseable pins and accessible lubrication points facilitate easy maintenance for extended service life.



ANGLED EJECTOR CYLINDER

The telescopic ejector cylinder is installed at an upward angle—keeping it away from debris, and directing compaction forces away from the body floor and towards its front mount location.



THICKEST BODY FLOOR

At 5/16" in the center and 1/4" on each side, Leach™ units boast the thickest standard floor in the industry.



LEACH™ TROUGH

Spanning the full body length, the distinctive Leach™ trough design, forms a built-in sump capable of holding up to 300 gallons of liquid. It also enhances stability with a lower center of gravity and improved weight distribution.



SMART CONTROL LOCATION

Unlike typical designs exposed to elements, Leach's Alpha™ III rear loader houses controls inside the body above the floor, shielded from dirt and debris.

*Compaction ratios will vary based on commodity and environmental factors

Alpha™ III Specifications

Body Specifications	Residential	Light Commercial
Body Trough Floor	5/16" 50W 50,000psi	5/16" 50W 50,000psi
Body Sides	10ga A1011 80,000psi	10ga A1011 80,000psi
Body Roof	10ga A1011 80,000psi	10ga A1011 80,000psi
Body Ramp Liners	-	1/4" A715 GR80 80,000psi

Cylinder Specifications	Residential	Light Commercial
Ejector Cylinder (14yd³ bodies)	1 stage 4-1/2" bore x 43" stroke	1 stage 4-1/2" bore x 43" stroke
Ejector Cylinder (16yd³ bodies)	2 stages 5-1/2" bore x 54-1/2" stroke	2 stages 5-1/2" bore x 54-1/2" stroke
Ejector Cylinder (18yd³ bodies)	2 stages 5-1/2" bore x 66-1/2" stroke	2 stages 5-1/2" bore x 66-1/2" stroke
Ejector Cylinder (20yd³ bodies)	2 stages 5-1/2" bore x 78-1/2" stroke	2 stages 5-1/2" bore x 78-1/2" stroke
Ejector Cylinder (25yd³ bodies)	3 stages 6-1/2" bore x 115-9/16" stroke	3 stages 6-1/2" bore x 115-9/16" stroke
Ejector Cylinder (29yd³ bodies)	4 stages 6-1/2" bore x 147-7/8" stroke	4 stages 6-1/2" bore x 147-7/8" stroke
Ejector Cylinder (32yd³ bodies)	5 stages 7-1/2" bore x 170-5/16" stroke	5 stages 7-1/2" bore x 170-5/16" stroke
Packer Cylinders	4-1/2" bore x 2-1/2" rod x 32-1/2" stroke	4-1/2" bore x 2-1/2" rod x 32-1/2" stroke
Carrier Cylinders	5-1/2" bore x 2-1/2" rod x 37" stroke	5-1/2" bore x 2-1/2" rod x 37" stroke
Tailgate Cylinders	4" bore x 3-1/2" rod x 32-11/16" stroke	4" bore x 3-1/2" rod x 32-11/16" stroke

Performance Specifications	Residential	Light Commercial
Packer/Carrier Cycle Time (with regen)	22-24 sec	22-24 sec
Packer/Carrier Cycle Time (without regen)	26-28 sec	26-28 sec
Tailgate Open	10 sec @ 700 rpm	10 sec @ 700 rpm
Tailgate Close (with Safety Flow limiter)	30 sec @ 700 rpm	30 sec @ 700 rpm

Body Dimensions	14yd³	16yd³	18yd³	20yd³	25yd³	29yd³	32yd³
A. Overall Length, Tailgate Closed (in.)	192	205	218	230	269	302	325
Overall Width (in.)	102	102	102	102	102	102	102
B. Overall Height Above Frame, Tailgate Closed (in.)	93	93	93	93	93	93	93
C. Overall Length, Tailgate Open (in.)	230	243	255	268	307	340	363
D. Overall Height Above Frame, Tailgate Open (in.)	154	154	154	154	154	154	154

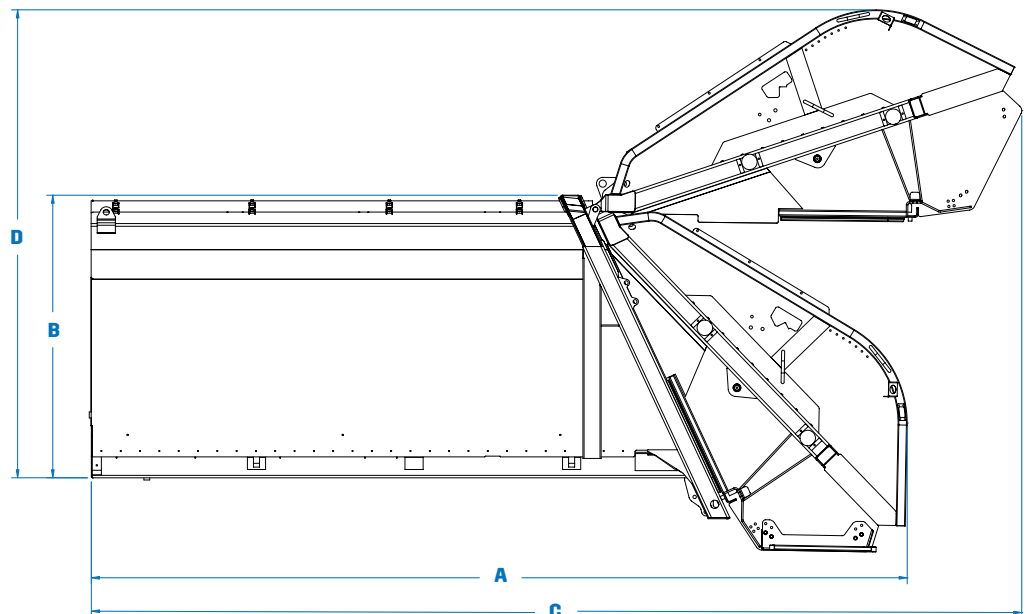
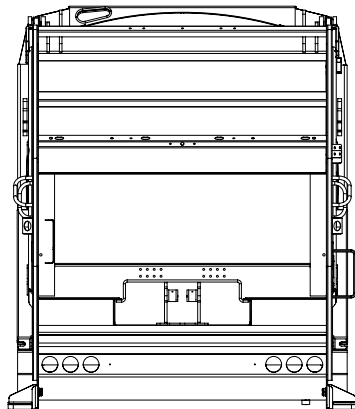

Hopper Specifications	Residential	Light Commercial
Hopper Size (yd³)	3.0	3.0
Hopper Opening Width	84"	84"
Hopper Opening Height	61-1/4"	61-1/4"
Hopper Depth	16"	16"
Loading Sill Below Chassis Frame	5"	5"
Hopper Floor	3/16" 100QT 100,000psi (AR450, 175,000 psi optional)	1/4" 100QT 100,000psi (AR450, 175,000 psi optional)
Hopper Sides (upper)	3/16" 50W 50,000psi (AR450, 175,000 psi optional)	3/16" 50W 50,000psi (AR450, 175,000 psi optional)
Hopper Sides (lower)	3/16" 50W 50,000psi (AR450, 175,000 psi optional)	1/4" 50W 50,000psi (AR450, 175,000 psi optional)

Ejector Specifications	Residential	Light Commercial
Ejector Panel Face Plate	3/16" 50W 50,000psi	3/16" 50W 50,000psi

Hydraulic Specs	Residential	Light Commercial
Pump	Gear	Gear
Pump Capacity	48 gpm @ 1350rpm	48 gpm @ 1350rpm
Max. Operating Pressure	2,150 psi	2,150 psi
Oil Reservoir	50 gal	50 gal

Packer-Carrier Specs	Residential	Light Commercial
Compaction ratio (lbs/yd³)	900	900
Packer Panel Face Plate	3/16" 50W 50,000psi	3/16" 50W 50,000psi
Carrier Panel Face Plate	7ga 50W 50,000psi	7ga 50W 50,000psi

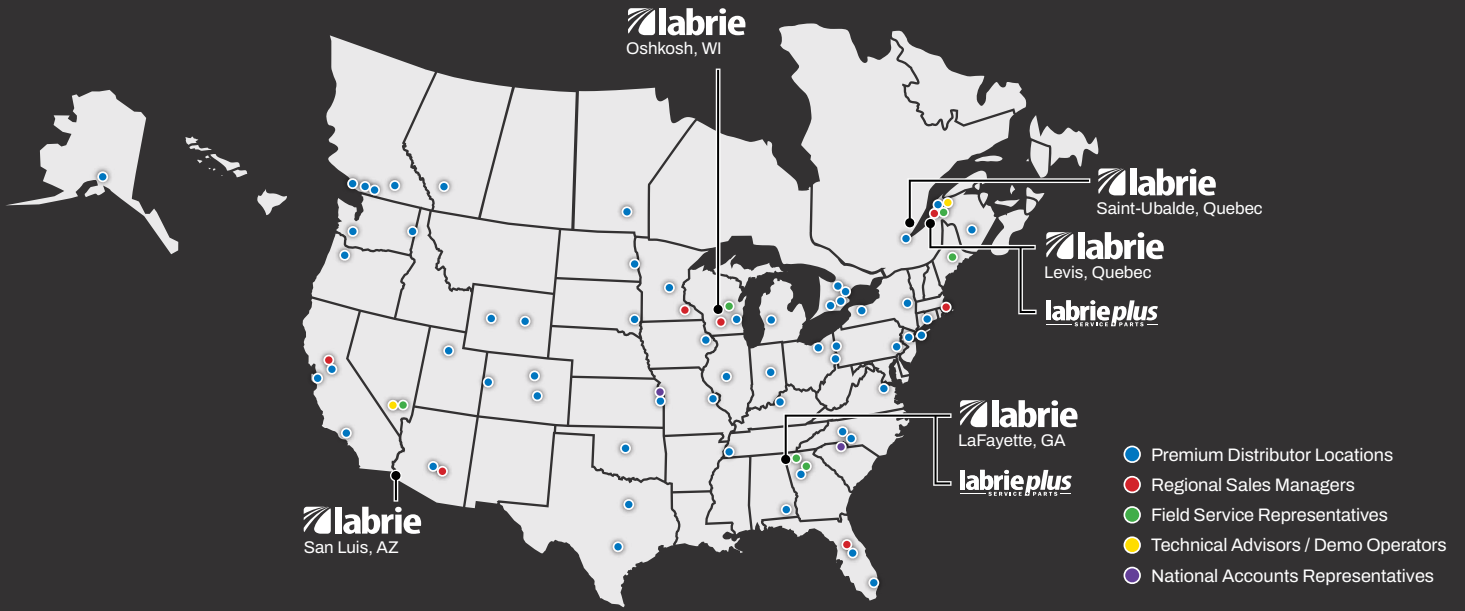

Our North American network is dedicated to quality.

Leach™ trucks are supported by over 30 top-tier distributors spanning across 50+ sites in the US and Canada, guaranteeing a commitment to driving excellence and providing expert support.



Opt for the Leach™ Pronto Stock Program when a pre-built model makes sense. Benefit from expedited delivery, cost savings, and a wide selection of models designed to cater to even the most demanding collection needs.



With Sourcewell, save time and money by combining the buying power of more than 50,000 government, education, and nonprofit organizations.



DRIVE EXCELLENCE™



175-B, route Marie-Victorin, Lévis, Quebec, Canada, G7A 2T3
 Toll Free: 1-800-463-6638 | Telephone: 418-831-8250
 sales@labriegrup.com | www.labriegrup.com



Serving Washington, Idaho, Montana, Oregon